

Façade cladding systems overview
Façade panel



Index

Field of application, characteristics	5
Principal joints	6
Fixing	9
Thermal expansion and contraction	9
Installation	9
Impact resistance	9
Appearance	10
Layout designs	12
Horizontal designs	13
Horizontal designs continued	14
Vertical layouts	14
Other layouts	15
Support and façade construction	16
Summary	17



Field of application, characteristics

This rainscreen system is especially suitable for flat façades. It can also be used on gently curving façades in which the panels run perpendicular to the direction of curvature. It is commonly used to clad soffits.

It presents a solid and formal appearance, is lightweight, very durable while being low maintenance, and quick and easy to install. The panels can be fixed in a horizontal or vertical direction, and the width of the shadow joint itself can be adjusted slightly, enabling the architect to reduce or emphasise the visibility of the joints as he wishes.

The panels are usually direct-fixed to a supporting structure consisting of metal rails. The hidden fixing is by way of screws or rivets. It normally uses eZinc® thicknesses of 1,0 and 1,2mm.



Diagram showing the façade panel system in a horizontal layout:

- 1. Façade panel
- 2. Recessed longitudinal shadow joint
- 3. Vertical joint liner

Principal joints

The longitudinal joint is a recessed joint 21mm deep and between 5 and 25mm wide, depending on the emphasis it is desired to be given. Different widths of joints may be combined in a single façade which allows the designer to reinforce some lines more than others.

The joint is normally made by roll-forming elZinc® strips into panels using specialist profiling machines. These machines profile material up to 1,0mm thick. The grooved edge is fixed to the substrate and the tongue of the next panel is slotted into the groove, covering the fixing.

The material needed to form the joint is approximately 100 to 130mm, depending on its width.



Vertical and horizontal roll formed panel joint

The longitudinal joint can also be made by folding (instead of roll-forming) the elZinc® strips into panels. The design of the joint should be such as to avoid rattling of the panels in windy conditions. An example of such a design is shown below, in which the tongue is bent just passed 90° so that its front edge fits snugly against the groove, thus preventing any movement. Alternatively a notch is made in the tongue after folding which ensures a snug fit in

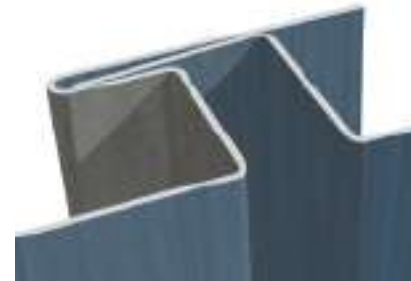

Example of a folded panel joint



Transverse joints vary in design and can depend on the orientation of the panels. The following are some of the more typical designs

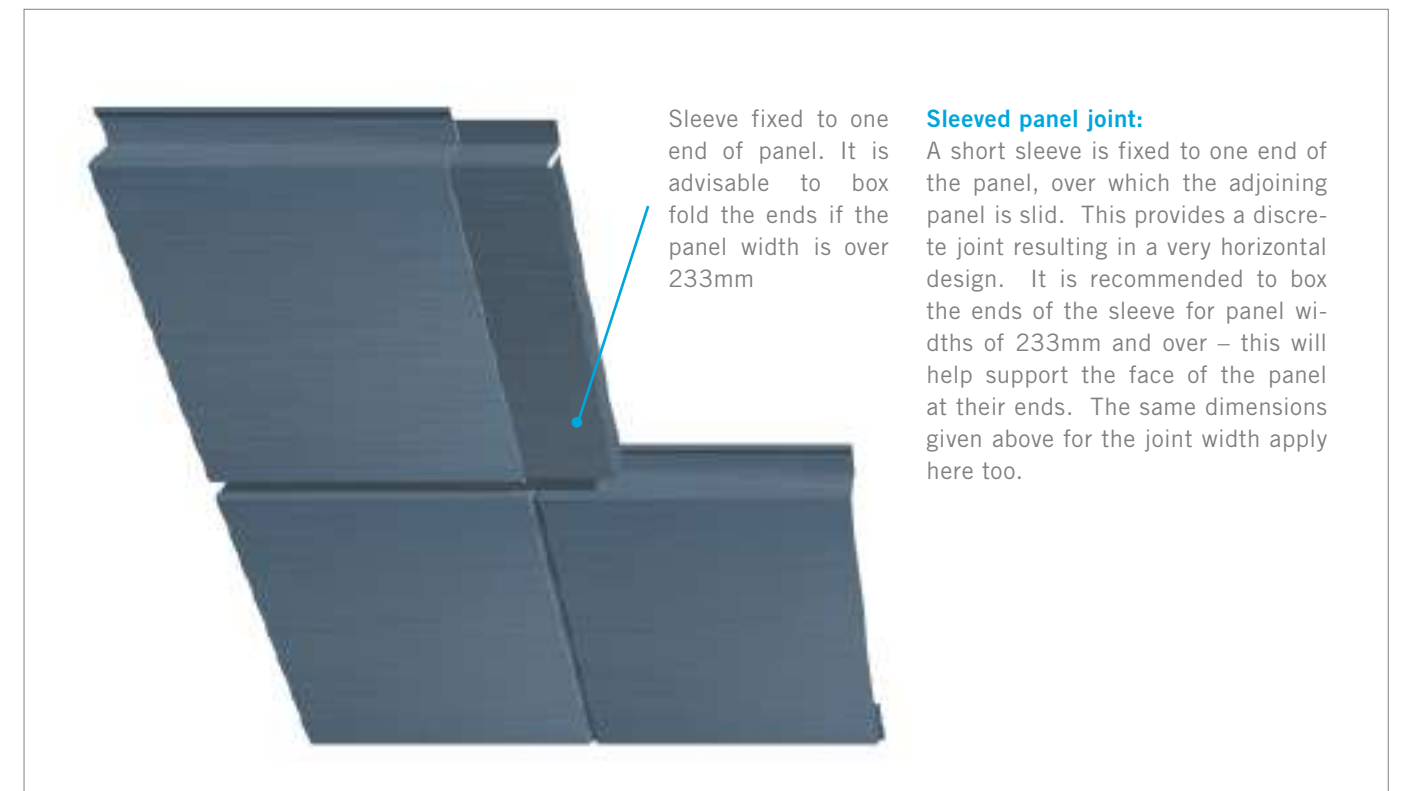
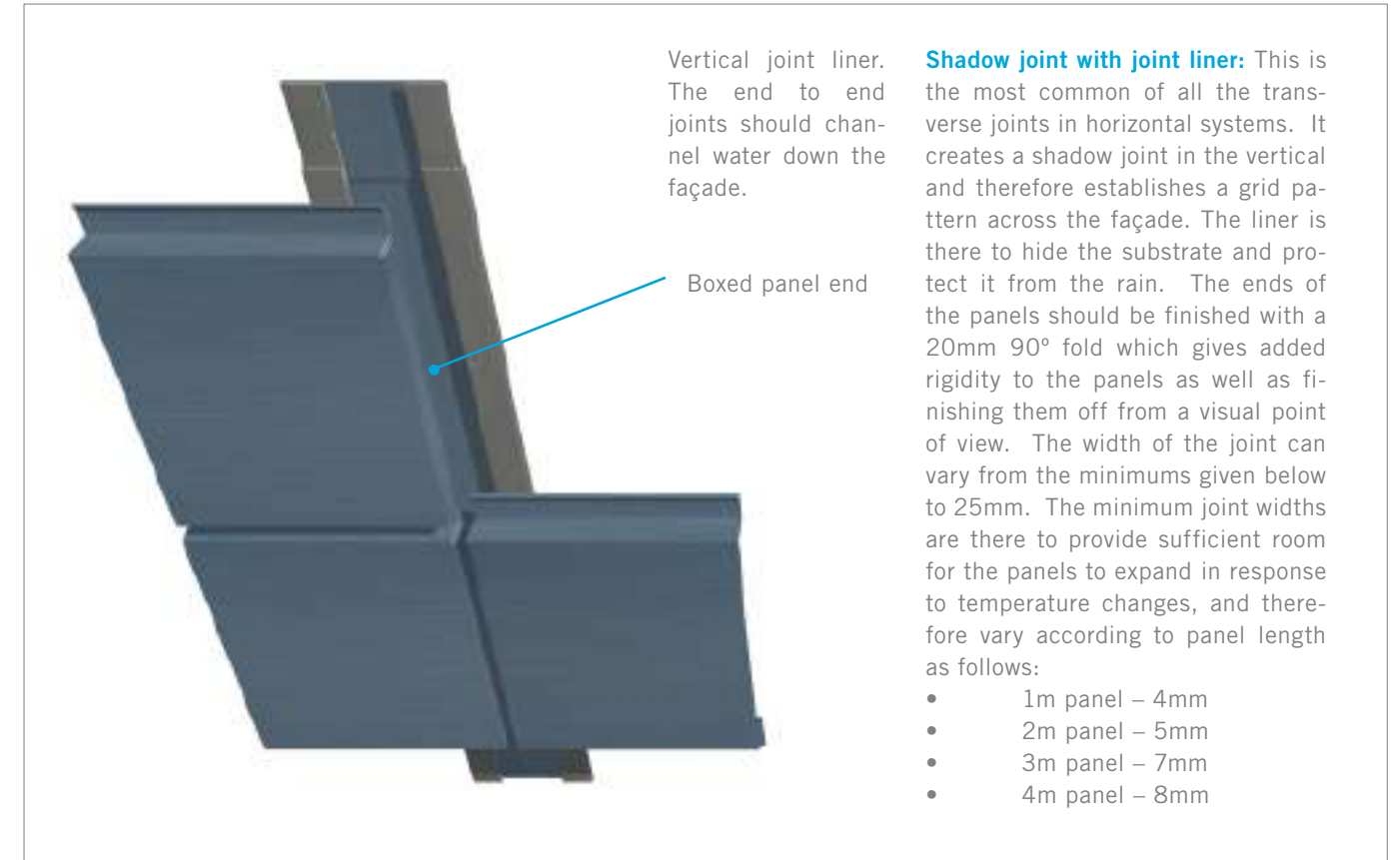

Transverse joints in vertical arrangements are often required to shed rainwater as well as hide the substrate behind, so they can be slightly more complex.

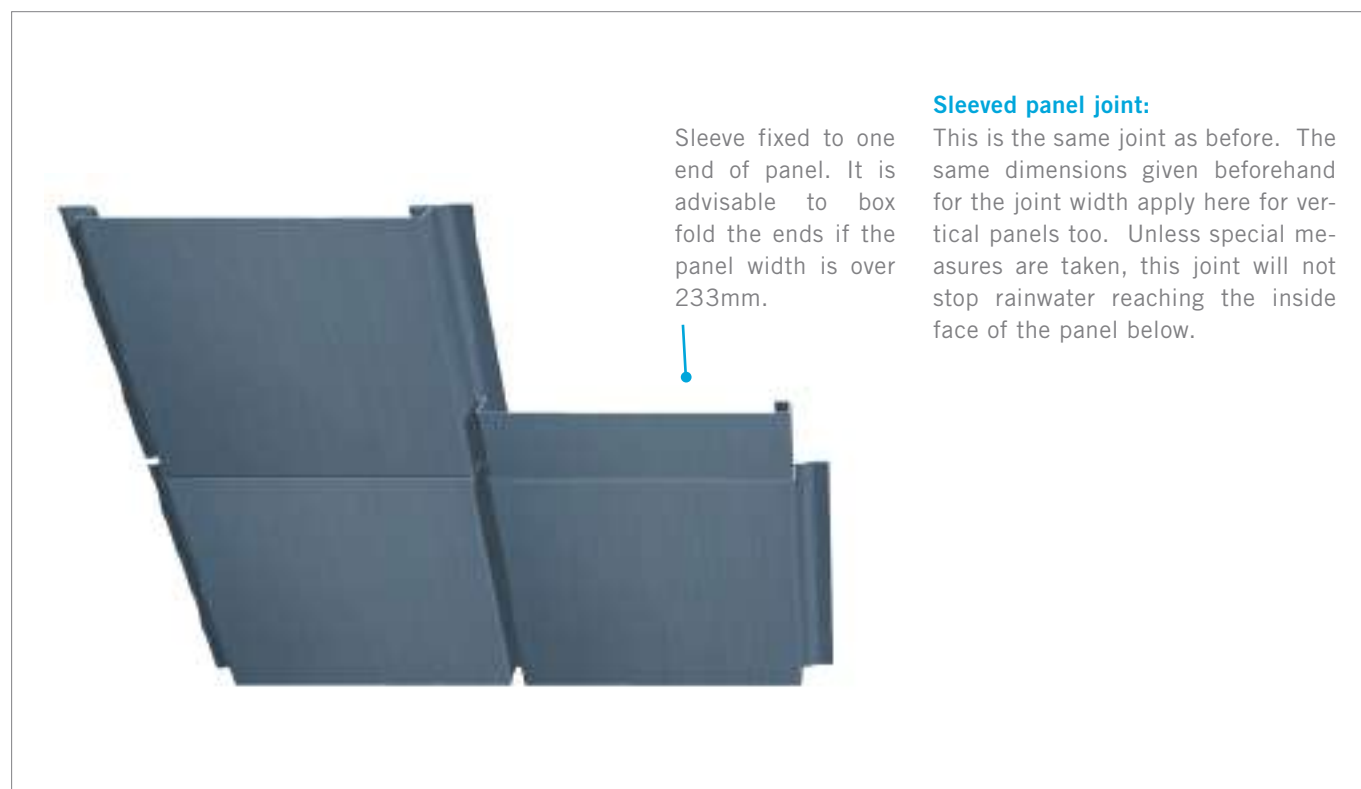
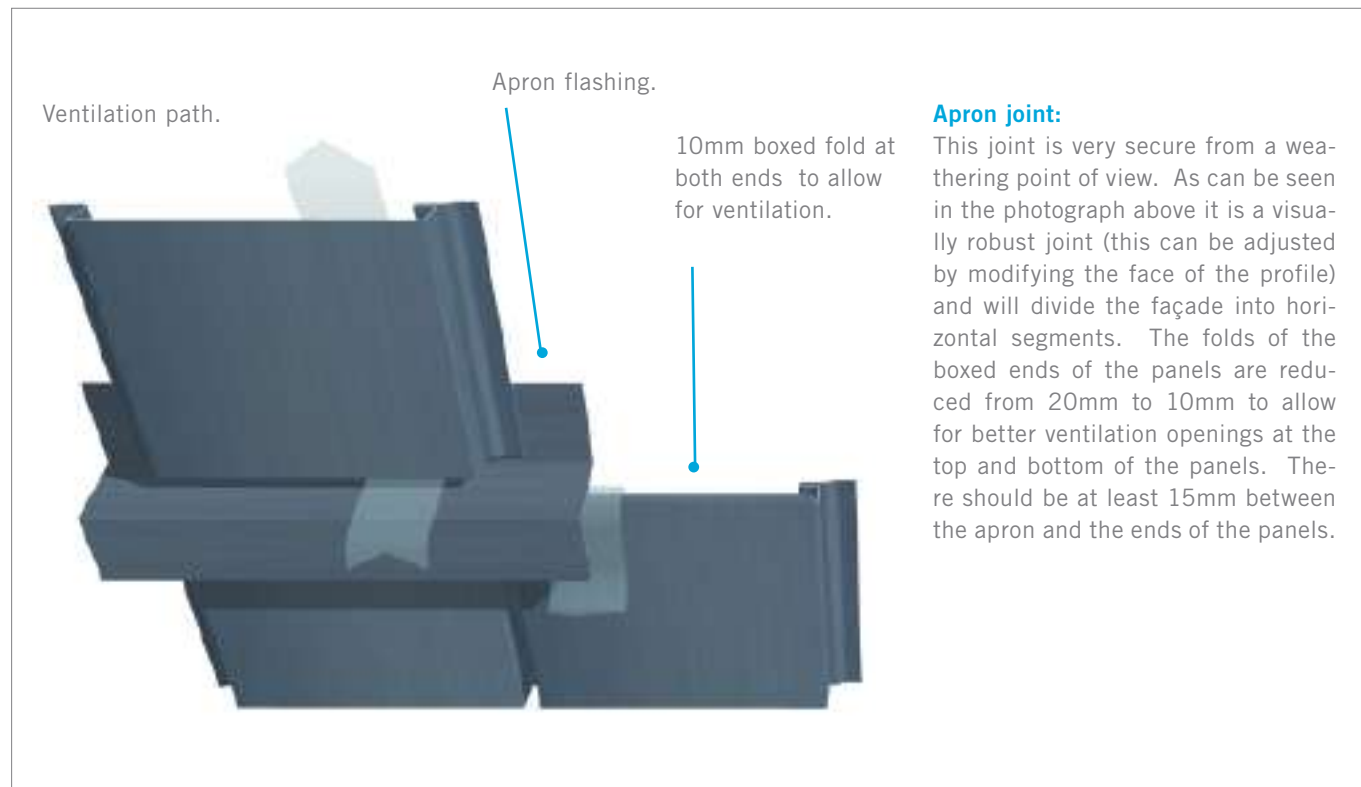

Fixing

Fixing of the elZinc® façade panels is direct by way of suitably corrosion resistant (normally A2 stainless steel) self-drilling screws. The screws are positioned in the flange of the grooved edge and fixed through to the metal profiles behind. Suitable rivets can also be used.

The distance between the fixings is pre-determined by the centres at which the supporting rails are fixed. A distance between rails of 50 to 60cm is normal and will be sufficient for most projects. For projects with especially high wind loading, please contact our technical advisory service.



Fixing the elzinc® façade panel

Thermal expansion and contraction

All movements generated by temperature changes in the panels are absorbed by the substructure, which must be able to flex slightly in response to these movements. These are always slight since panel lengths are limited to 4m, so this is achieved without any special supporting system.

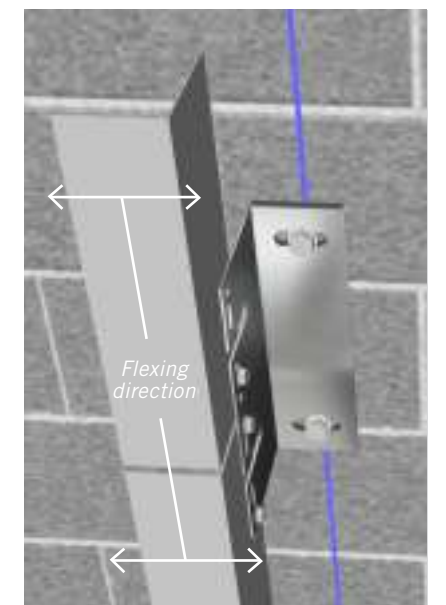

Flexing of 'helping hand' type wall anchor and rail

Installation

Horizontal panels are installed from the top down, whereas vertical panels are either installed right to left or left to right. The direction of installation does not affect the look of the joints.

Impact resistance

Since the panels are hollow and not backed by a continual support, at street level on some projects it may be considered necessary to reinforce their face to give added impact resistance. This can be easily achieved by gluing a ridged backing material to the inside face of the elZinc® panels. In vertical layouts this may block the ventilation of the façade (since vertical panels often ventilate through their own profile), so the supporting system is modified slightly to accommodate for this - please consult our technical advisory service for more details.

Appearance

The slot-in façade panel gives a formal appearance to the building. The strength of the cladding's longitudinal lines can be determined by choosing the appropriate joint width (from 5 to 25mm). These joints can therefore vary from quite discrete to rather bold. The transversal joints also have a large influence on the look of the façade, and can be chosen either to subdue or accentuate the grid effect these joints cause.

The elZinc® panels are normally set out in the horizontal or vertical, however for design reasons they are sometimes set at a different angle.

It is important to coordinate the position of window and door openings in the façade with the grid layout of the panels to give an ordered appearance.

Although this is a thin metal gauge system, waviness in the panel face is normally considered less attractive here than in traditional systems. Panel thicknesses and widths are therefore selected to minimize this. It is important that the supporting rails are well aligned and plum. These measures, taken together with the excellent flatness and low residual tension of all of the elZinc® products, ensure that the roll-formed panels façade panels have an optimum appearance.



Layout designs

The principal factors affecting layout design are the panel dimensions and joint widths. As a rough guide, assuming rails every 50 or 60cm, panel dimensions should respect the following table:

Grid panel width	Material thickness
233 to 300mm	1,0mm
300 to 400mm	1,2mm

More detailed guidance, including relevant wind loading information, is available from our technical advisory service. 1,2mm thick material cannot normally be roll formed and must therefore be folded, adding some extra cost to the cladding. However, this helps to produce very flat panels since folding always produces less waviness than roll forming. The wider the shadow joint the more noticeable it becomes and this can be used to good effect by the architect to either diminish or enhance the joints. Narrow joints can also be combined with wider joints to create visual blocks of panels.

Openings in the façade should be planned to fall within the joint grid, allowing for the face widths of the sill, jambs and lintel. This width is normally around 5cms, but can be varied slightly to adjust the total width and height of the openings to the panel grid.



Horizontal designs

We have drawn some common horizontal layout designs here. Other designs are possible – please contact us for more examples. The images are shown with a shadow effect for clarity.

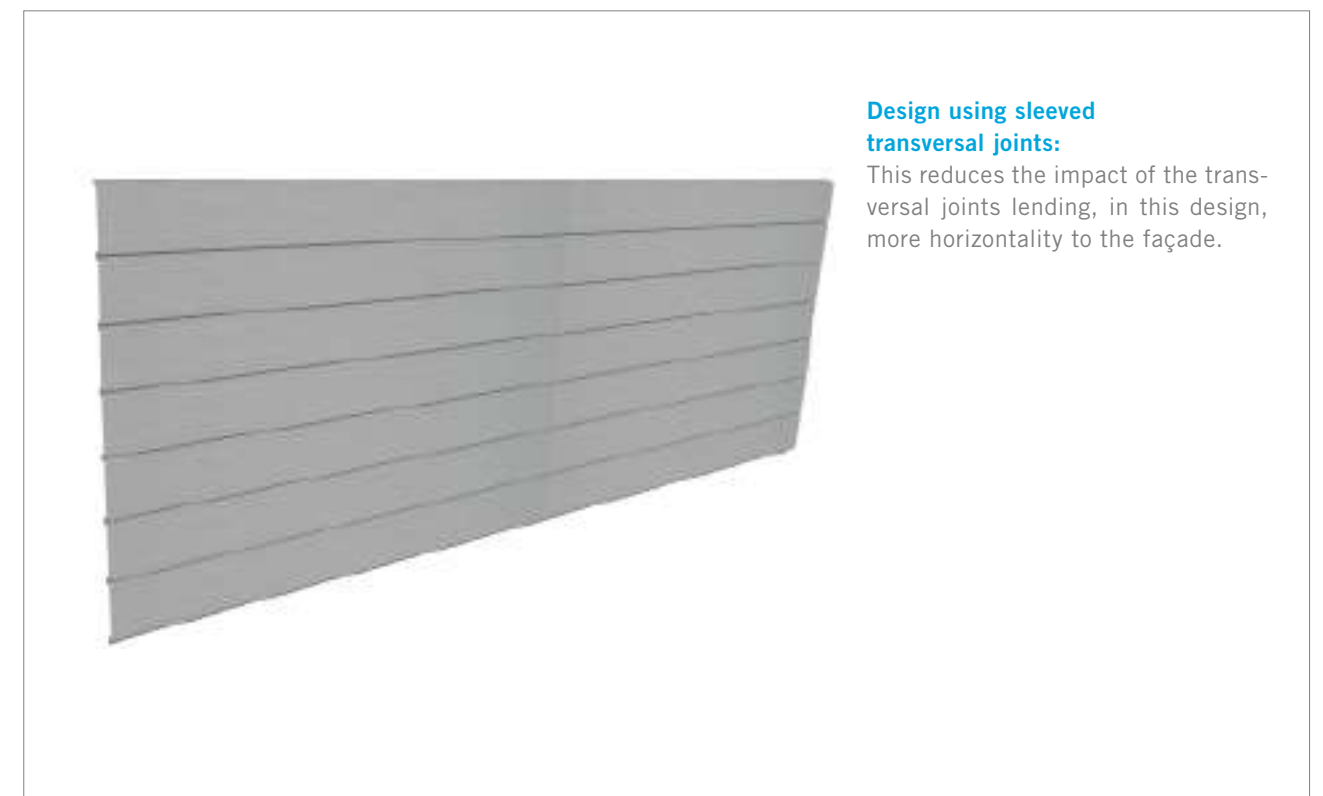
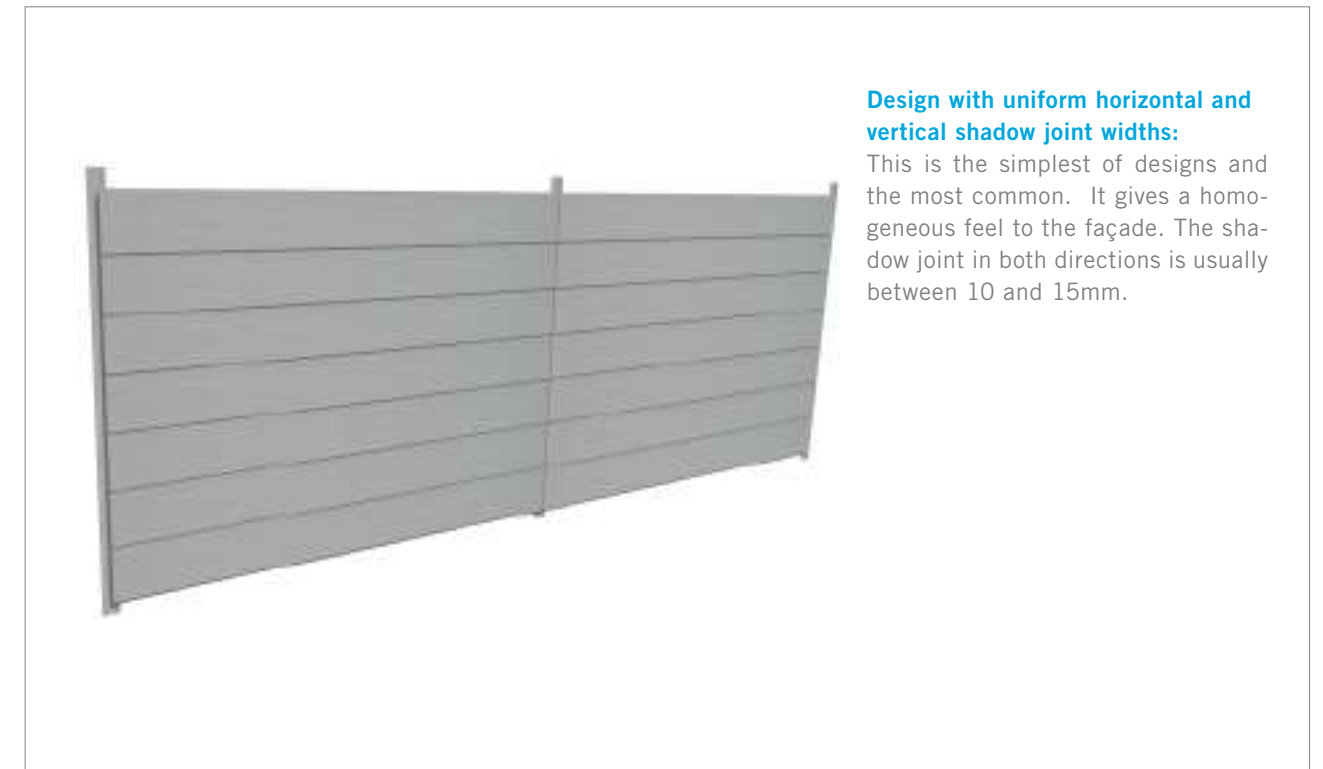

Horizontal designs continued

Design using different joint widths:

This 'frames' blocks of panels and can create the illusion (at a distance) of large panel sizes. The heavier joints are normally made to coincide with openings.



Vertical layouts

The choice of the transversal joint has a large bearing on the look of the façade as the aproned joint is visually bold. As previously mentioned, it is the more weather-tight of the two, so is recommended for exposed conditions, for tall buildings, and for any cladding where rainwater on the inside face of the cladding is required to be kept to a minimum.

Vertical design using the apron joint:

This joint is often made to coincide with window lintels to keep the façade nicely ordered.



Other layouts

Panels are sometimes set at an angle somewhere between the horizontal and the vertical, but this is not as easy to accomplish as with traditional systems (standing seam and flat lock panels), especially if the façade is punctured by openings. Please contact our technical advisory service if such a design is desired.

It is possible to combine horizontal and vertical layouts on the same façade. This necessitates careful planning of the substrate and installation direction.



Design combining vertical and horizontal panels:

This is just one example of the possibilities available. The setting out of the supporting profiles is important as they must be perpendicular to the panel and therefore divided up to match the panel design. In addition some of the panels need a slightly different profile. The costs here are slightly higher than a normal layout, however, this design does not present any further significant complications and can certainly bring to life large façades which otherwise might be rather monotonous.

Support and façade construction

In this ventilated façade (rainscreen) system the façade panels are self-supporting over short distances and are therefore fixed to a sub-structure consisting of a system of rails. These rails are either directly fixed back to the main structure behind (if it is flat and plumb enough and the thermal bridges are not a problem) or indirectly via wall brackets that provide for adjustment and therefore permit a flat and plumb sub-structure to be cons-

tructed. The rails are metal, and should have a 50mm or greater face width against which the panels are fixed. The elZinc® panels are ventilated by an air layer of at least 2cm between themselves and the insulation. The insulation must be such that it does not slump and close the layer. In order to control air leakage through the façade the structure must be airtight behind the elZinc® panels, so if the supporting wall is lacking in this regard, an air-

tight breather membrane should be installed. If installed over the insulation, where it will also protect the insulation from any possible water 'jumping' the air gap, it may require some changes in the supporting structure. For more detailed information on supporting materials and wall construction, please consult our technical documentation.

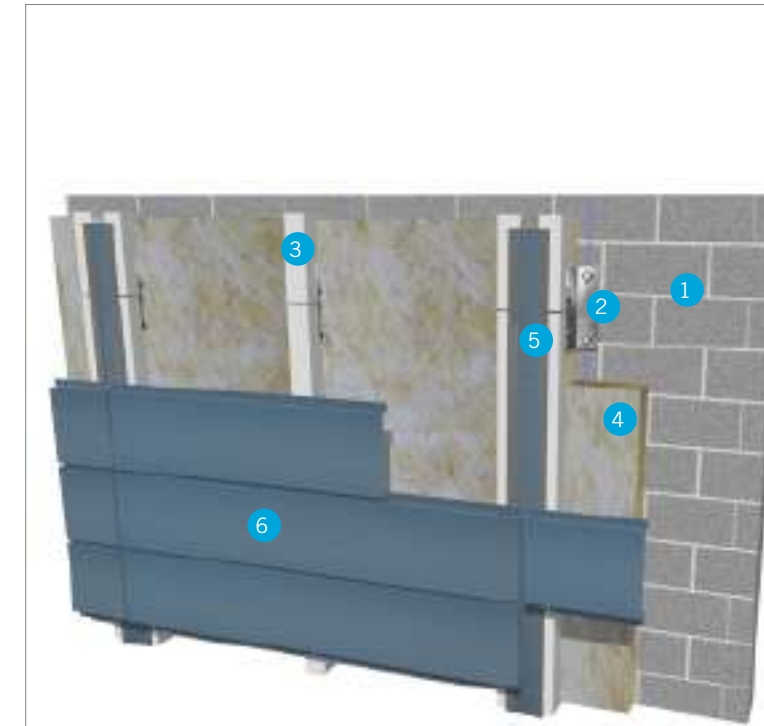

Horizontal design:

1. Concrete block structural support
2. Adjustable wall bracket
3. Metal rails
4. Insulation and air gap
5. Joint liner
6. Façade panel cladding

A thermally insulating insert can be fitted between the anchors and the wall to break the thermal bridge if required. The anchors are adjustable and allow for imperfections in the support, and their dimensions should be selected to give a minimum gap of 2cm between the outer faces of the profile and the insulation. The anchor and 'L' profile will flex slightly in a horizontal direction to absorb the thermal movement of the panels. At the ends of the panels there is effectively an expansion joint covered by the liner (which is fixed to allow for this movement).



Vertical design:

1. Concrete block structural support
2. Adjustable wall bracket
3. Metal rails
4. Insulation and air gap
5. Horizontal apron flashing
6. Façade panel cladding

The panels ventilate through their own profile. The anchor and 'L' profile will flex slightly in a vertical direction to absorb the thermal movement of the panels. At the ends of the panels there is effectively an expansion joint, flashed by the apron. The ability of the rails to withstand the weight of the panels without flexing too much should be checked, or a three component system installed (horizontal 'z' profiles over vertical rails)

Summary

CHARACTERISTIC		OBSERVATIONS
Field of application	Flat and gently curved façades, soffits	For curved façades it is more economical to use a layout that sets the panels perpendicular to the curve – curving panels is expensive
Principal joint	Shadow joint 21mm deep. The width can vary from 5mm to 25mm. Between 100 and 130mm are needed to form the joint. This can be fine-tuned by adjusting the fixing flange length	For projects with high design wind loading or designed with joint widths on the wider side of the range, it may be necessary to stitch the panels together in the joint using rivets to prevent popping out of the panels in windy conditions. In wet climates where water could be retained in a 5mm gap for long periods, a minimum joint width of 10mm is advised. Please contact elZinc® for further advice if in doubt.
Minimum thickness	0,8mm	The correct thickness is principally selected according to the width of the panels
Maximum thickness	1,2mm	
elZinc® finishes	elZinc® Natural, elZinc Slate®, elZinc Rainbow®, range of finishes on demand	Natural, mill finish zinc is not generally chosen for façades due to its initial shine and the natural weathering characteristics of zinc, which can be rather patchy at first on vertical surfaces.
Weather tightness	This is a back vented and drained rainscreen system, and some rain will filter through to the inside of the outer layer.	Protecting the insulation with a breather membrane may be advisable in some locations.
Fixing method	Direct and using corrosion resistant screws or rivets	_____
Layout designs	Horizontal and vertical.	_____
Grid panel width	Normally 233, 300 and 400mm.	Grid panel width is the centre to centre measurement
Panel length	Up to 4m	_____
Panel depth	25mm	_____
Substrate	Metal rails at 50 to 60cm centres, able to flex slightly to allow for thermal movements in the panels	_____
Wall construction	Ventilated with a ventilation space behind the panels	Ventilation layer a minimum of 2cm deep. It is important that the structure behind the air gap is airtight.
System weight	From about 8 to 11kgs/m ² , zinc only	_____
Cost	Medium	It is one of the most economical panel systems for façades
Means of elevation for fixers	Platforms or scaffolding	Ideally the positioning of the scaffold anchors should be agreed upon with the installer of the elZinc® cladding
Variations		_____

Samples

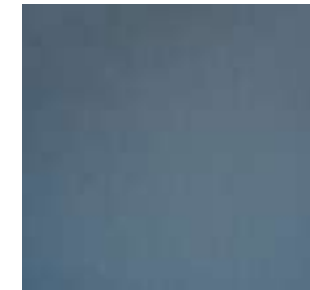

elZinc Rainbow® blue

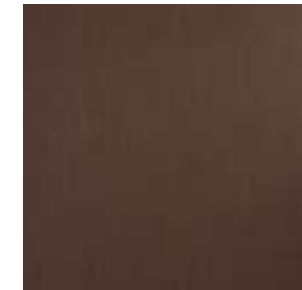

elZinc Rainbow® red

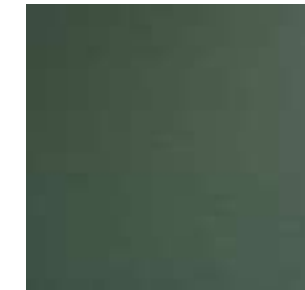

elZinc Rainbow® green



elZinc® natural



elZinc Slate®

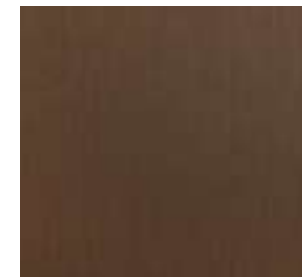

elZinc Rainbow® brown



elZinc Rainbow® gold



elZinc Rainbow® black

Note: The colours shown in this document are for illustrative purposes only and should not be taken as representative of the real finishes. Please request our sample card to see the real elZinc® finishes.

For more detailed technical information, please consult our technical literature or contact our technical advisory Service.



ASTURIANA DE LAMINADOS, S.A. has developed the instructions and recommendations herein with the aim of providing a better service for its customers. It is generic information for standard installation of elZinc® products in a European climate.

This information must not substitute the considerations and requirements that, in each project, architects, designers and consultants may offer.

ASTURIANA DE LAMINADOS, S.A. does not accept any responsibility therefore for any damage incurred to third parties, directly or indirectly by the misapplication, misinterpretation or general incorrect use of the information contained herein, exonerating itself from all and any responsibility deriving from this document, within the legal framework established and applicable in each case.

We remind readers that ASTURIANA DE LAMINADOS, S.A. provides an advisory service to assist in the interpretation and use of this information should any doubts arise in this regard.

Factory

Asturiana de Laminados, S.A.

Polígono Industrial de Villallana,
Parcela 1
33695 Villallana
Tel (0034) 98 410 60 00
Fax (0034) 985 49 32 02

Headquarters

Asturiana de Laminados, S.A.

Polígono Industrial de Olloniego,
Parcela C1
33660 Olloniego
Tel (0034) 98 567 60 00
Fax (0034) 98 569 20 00

APRIL 2014

www.elzinc.co.uk

elzinc@aslazinc.com